

# 12•20-RTM

## RETERM & FOOD HOLDING OVEN WITH ROLL-IN CART



- HALO HEAT . . . a controlled, uniform heat source that gently rethermalizes or regenerates prepared meals and bulk foods to proper serving temperatures and automatically converts to hot food holding to provide a safe and prolonged holding environment for rethermalized foods.
- Rethermalizes foods within the two-hour time period required by U.S. Food Code.
- Close temperature tolerance and uniform heat distribution reheats evenly, maintaining an ideal serving temperature throughout the cabinet.
- Retherm oven is furnished with a roll-in cart (trolley).
- An optional roll-in cart features removable pan slide panels to stack optional wire baskets for individual entrée rethermalization.
  - Up to twenty-four full-size pans (GN 1/1) or twelve sheet pans.
  - Up to twenty-six wire baskets to retherm individual entrées.
- Non-magnetic stainless steel interior resists corrosion.
- Manual control configurations include an adjustable retherm thermostat, holding thermostat, and 4-hour timer.
- Electronic control models provide complete operating function, automatic preheating, and memory storage for up to eight individual operator set retherm programs. Digital display monitors inside air temperature of the oven programmed operating parameters.



Single compartment, mobile oven with a retherm thermostat temperature range of 100° to 400°F (38° to 204°C) and a holding temperature range of 60° to 240°F (16° to 116°C). Oven includes 20 gauge stainless steel exterior, door handle with positive latch, two (2) exterior handles for maneuverability, and is supported by four (4) 5-inch (127mm) heavy duty casters, 2 rigid and 2 swivel with brake.

Electronic control includes a 4-digit LED display, ON/OFF key, retherm temperature key, and holding temperature key. Control also includes retherm mode count-down timer, up and down arrow keys for time and temperature adjustment, miscellaneous indicator lights for operational status, and a start key. The control features eight (8) programmable menu keys with the ability to set individual retherm, hold, and time parameters. The control has an automatic preheat program and built-in lock out feature.

Manual control configuration includes an ON/OFF power switch, adjustable retherm thermostat, and holding temperature thermostat. Control also includes a 4-hour timer, and an exterior gauge to monitor internal oven air temperature.

Each retherm oven is furnished with one (1) roll-in cart (trolley) which features non-tilt pan support rails.

- MODEL 12•20-RTM/ e: Single compartment mobile oven with electronic control
- MODEL 12•20-RTM: Single compartment mobile oven with manual control configuration

### FACTORY INSTALLED OPTIONS

- Left-hand door hinging is standard.
  - Specify right-hand doors as a special order.
- Entrée containers are not included.
- Optional HACCP Documentation web-based software provides the ability to monitor, store, and print all relevant data.
- Optional HACCP with Kitchen Management web-based software provides the ability to program, control, monitor, and store all relevant data.



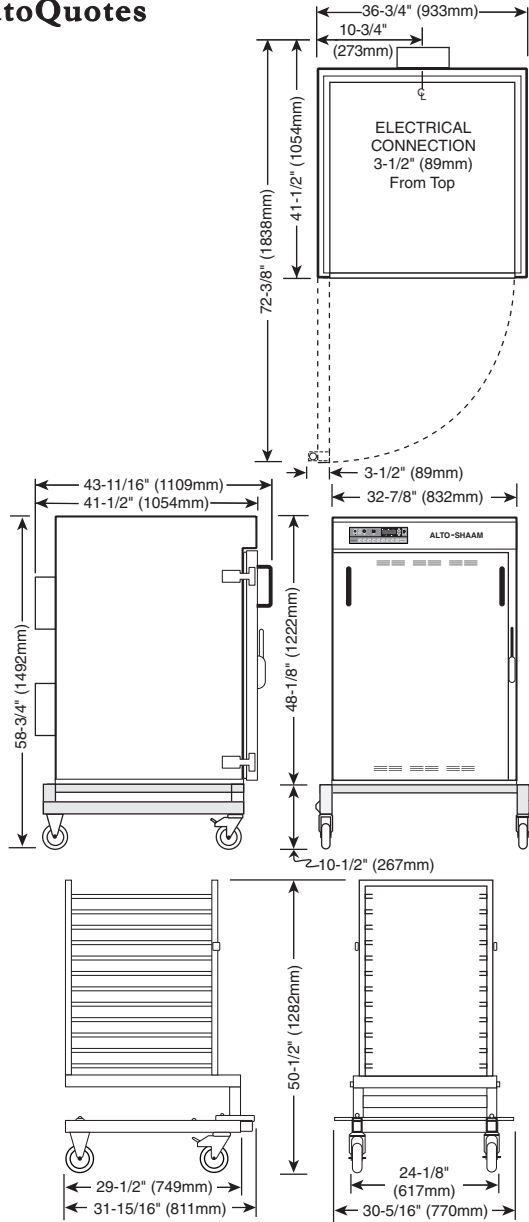

### DIMENSIONS: H x W x D

#### EXTERIOR:

58-3/4" x 36-3/4" x 43-11/16" (1492mm x 933mm x 1109mm)

#### INTERIOR:

39" x 28-1/8" x 35" (991mm x 714mm x 889mm)

### ELECTRICAL

VOLTAGE	PHASE	CYCLE/ HZ	AMPS	kW
208-240 (AGCY)	1	60	30	7.2
at 208	1	60	31.8	6.6
at 240	1	60	30.4	7.3
208	3	60	AVAILABLE	
240	3	60	AVAILABLE	
230	3	50	AVAILABLE	
380-415 (AGCY)	3	50/60	12	7.2
at 380	3	50/60	10.9	6.2
at 415	3	50/60	11.9	7.3

NO CORD OR PLUG INCLUDED

### PRODUCT \ PAN CAPACITY

288 lbs (131 kg) MAXIMUM

VOLUME MAXIMUM 180 QUARTS (228 LITERS)

#### PANS:

Twenty-four (24) FULL-SIZE PANS GASTRONORM 1/1  
 20" x 12" x 2-1/2" 530mm x 325mm x 65mm

Twelve (12) FULL SIZE SHEET PANS  
 18" x 26" x 1"

WITH OPTIONAL WIRE SHELVES

#### WIRE-ENTRÉE BASKETS:

Twenty-six (26) #53 13" x 20" (330mm x 508mm)

ENTRÉE PANS PER BASKET: 8

ENTRÉE PANS PER CART: 208

ENTRÉE PAN SIZE: 6-1/2" x 5" (165mm x 127mm)

#### ROLL-IN CART (TROLLEY) #5814

— Twelve (12) pan support rail positions

2-5/8" (67mm) vertical spacing between rails

21-1/8" (537mm) horizontal width between rails

### INSTALLATION REQUIREMENTS

- Oven must be installed level.
- The oven must not be installed in any area where it may be affected by steam, grease, dripping water, extreme temperatures, or any other severely adverse conditions.

### CLEARANCE REQUIREMENTS

6-inches (152mm) at the back, top, and both sides

### WEIGHT

NET: 405 lb (184 kg)

SHIP: 510 lb (231 kg)

CRATE DIMENSIONS: (H x W x D)

64" x 44" x 47" (1626mm x 1118mm x 1194mm)

### OPTIONS & ACCESSORIES

HACCP Network Options (ELECTRONIC CONTROL ONLY)

REFER TO SPECIFICATION #9015 FOR APPLICABLE PART NUMBERS

HACCP Documentation

HACCP with Kitchen Management

Cart, Roll-in

with Removable Pan Rail Supports

5000723

Preheat Sealing Strip

1000664

Probe, internal product temperature (ELECTRONIC CONTROL ONLY)

AVAILABLE

Stainless Steel Wire Shelf

SH-22473

— TO ACCOMMODATE FULL-SIZE SHEET PAN

Wire Entrée Basket

— 13" x 20" #53 (330mm x 508mm)

BS-25591